



JULY-AUGUST, 1960

HAM NEWS



HIGH-POWER MOBILE RADIO SYSTEMS

WB0LD and W8WFH, above, have designed and constructed high-power mobile amateur radio stations for their station wagons which give them home-station performance on the highway. G-E HAM NEWS is proud to present a series of three articles which describe their systems, starting in this issue. Techniques for power supplies, receivers, and linear amplifiers for CW and SSB communication will be covered.

PART I — In this issue: POWER SUPPLY IDEAS — A 3-phase AC power system, and high voltage power supply circuits.

PART II — September-October, 1960: CRYSTAL CONTROLLED CONVERTERS — Single-band, and bandswitching type converters for mobile reception.

PART III — November-December, 1960: MOBILE LINEAR AMPLIFIER — A compact linear amplifier designed especially for mobile operation.

Copyright, 1960, by General Electric Company

in this issue . . .

Scanning the Spectrum.....page 2

MOBILE POWER SUPPLY IDEASpage 3

General Electric Announces "Compactron" Multi-function Devicespage 8

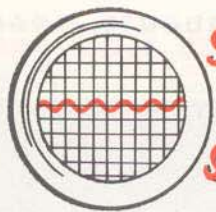

SCANNING the SPECTRUM

MEET THE AUTHORS . . .

W8DLD — A. F. (Al) Prescott, is an engineer with the electronics laboratory at General Electric's Cuyahoga Lamp Plant.

W8WFH — W. C. (Bill) Loudon, is technical counselor in Discharge Advance Engineering at G-E's Large Lamp Department.

Both of these operations are located at General Electric's Nela Park, in Cleveland, Ohio, home of our world-famous Lighting Institute.

Al and Bill have amassed years of experience in developing radio equipment — and their 3-phase power system — for mobile use. Their present SSB installations reflect the results, and are nearly all home made, including the antennas, except for the Command set receivers. Their stations operate on all frequencies from 3.5 to 29.7 megacycles, but their favorite channels for daily mobile operating are from 14,250 to 14,300 kilocycles.

Their phasing type SSB exciters have some unusual circuits and ideas, so the readers of *G-E HAM NEWS* will be seeing novel features of this equipment in coming issues. The receiving systems and a linear amplifier will be described in the next two issues.

Dramatic evidence of the reliability of their equipment was illustrated by their being able to keep three-times-daily schedules while separated at times by more than 2,000 miles during vacation motoring trips in 1959 and 1960.

KING-SIZE KIT . . .

While browsing through a recent issue of *Broadcast Engineering* magazine, I saw an article describing what appears to be the largest electronic equipment in kit form on the market — a one kilowatt broadcast transmitter!

The kit was designed for simplified assembly — which should take about 100 hours, according to the manufacturer — but obviously is a project for a person with some experience in the broadcast equipment field. When the transmitter is completed, the manufacturer sends a representative to run proof-of-performance tests in accordance with FCC regulations.

NOTE: The disclosure of any information or arrangements herein conveys no license under any patents of General Electric Company or others. In the absence of an express written agreement to the contrary, the General Electric Company assumes no liability for patent infringement (or any other liability) arising from the use of such information by others.

ADDED ALTERNATOR INFO . . .

The alternators which form the key component of the mobile power system described in this article were manufactured by the Leece-Neville Co., 5109 Hamilton, Cleveland 14, Ohio. They are available from automotive parts suppliers, or often may be obtained secondhand when operators of two-way radio equipped vehicle fleets trade in their old equipment for new models.

These alternators also may be ordered as optional accessories on many makes of U.S. automobiles. W8DLD and W8WFH ordered their station wagons factory-equipped with the alternator systems. And, of course, similar alternators will be supplied as standard equipment on several makes of 1961 automobiles. While these alternators may not have the reserve power capacity of the Leece-Neville system, mobileers with equipment requiring up to 300 watts of DC power can take advantage of the 3-phase power available by stepping it up directly to high voltage.

This eliminates the usual three steps of converting the 3-phase AC power into DC, then back to AC in a vibrator or transistor oscillator, and finally back to DC in the high voltage transformers and rectifiers.

NEW MOBILE MANUAL . . .

A new and revised edition of the *Mobile Manual for Radio Amateurs* has just been published. This second edition, edited by the headquarters staff of ARRL, is a comprehensive digest of more than 80 articles from QST on the subject of amateur mobile, emergency and portable equipment.

It's a valuable how-to-do-it manual for the mobile enthusiast; contains 279 pages of editorial text, plus index, and a large number of photographs and diagrams. Examine ARRL's newest handbook at your nearby electronics parts distributor.

LOG FORM QSL's GONE . . .

By the time this item appears in print, our supply of the G-E Log Form QSL card will be completely exhausted. We called your attention to the dwindling supply in the March-April issue. So please don't send in any more orders because we will only have to return them to you.

However, work is progressing on the Third Bound Volume of *G-E HAM NEWS*, and the new *G-E HAM NEWS* SSB Package, as described in this column in the May-June issue. We're planning to have them available by December of this year, both from G-E Tube distributors, and by mail order from the *G-E HAM NEWS* office.

73 until next issue,

—Lighthouse Larry

MOBILE POWER SUPPLY IDEAS

By A. F. Prescott, W8DLD, and W. C. Loudon, W8WFH

TODAY'S MORE POWERFUL mobile amateur radio equipment can overload even the larger electrical systems in late model automobiles. Solve this problem by installing a constant voltage, variable-frequency, 3-phase, AC power system—large enough for even a kilowatt mobile rig—using the principles and ideas described in this article.

With many mobile radio installations now requiring 200 watts and more power from automotive electrical systems, it is usually necessary to run the car's engine when this equipment is operated for more than a few minutes at a time to avoid discharging the battery. The standard automotive electrical system, as shown in Fig. 1, just wasn't designed for this purpose.

Many commercial, police and taxi vehicles have 3-phase AC alternators installed to provide extra power for two-way radio equipment. One manufacturer, Leece-Neville, supplies either 6-volt, 100-ampere, or 12-volt, 30-ampere alternator systems, rated at 600 watts output (see page 2 for details).

However, the 600-watt limitation is due mainly to the rectifier connected to the alternator output to change the 3-phase AC cur-

rent into direct current, as shown in the block diagram of Fig. 2. Over 200,000 miles of field "testing" on the alternators installed to power W8DLD/M and W8WFH/M have proven this system capable of supplying more than 1-KVA of power, even under summer driving conditions.

Note that the rectifier is used mainly for battery charging and other normal needs of the automotive electrical system. The high voltage DC power supply can be fed directly from the alternator, avoiding the less efficient method of first rectifying the 3-phase AC power into direct current, and then obtaining high voltage with a dynamotor, transistorized D-C-to-DC converter, or vibrator power supply.

Voltage regulation of the alternator system is very good. The "variable frequency" mentioned above occurs from changes in engine speed, from 100 cycles with the engine idling, to nearly 1,000 cycles at top speed. However, modern power transformers, even though rated for 60-cycle operation, are capable of operating efficiently over this wide frequency range. And, usually the 60-cycle ratings may be considerably exceeded at the higher supply frequencies.

(continued on page 5)

FIG. 1. BLOCK DIAGRAM of a typical 12-volt DC automotive electrical system. Approximately 200 watts of power may be drawn on an intermittent basis to operate mobile radio equipment. Usually the automobile engine must be kept running if more than a few minutes operation of radio equipment is attempted to keep the storage battery charged.

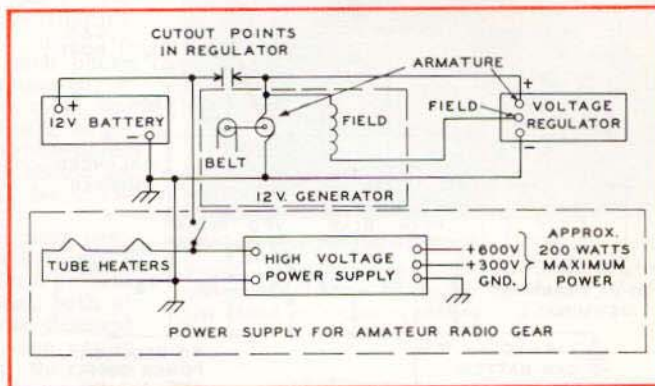
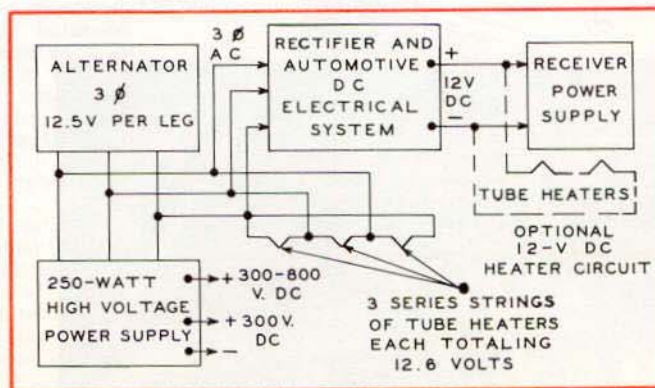

FIG. 2. BLOCK DIAGRAM of an alternator type automotive generating system which can be installed in place of the conventional DC generator. The alternator generates 3-phase AC power which is then rectified and used to charge the storage battery. The AC power is fed into a 3-phase high voltage power supply of up to 250 watts capacity. Tube heaters in radio equipment may be operated either from the DC battery power, or from the AC alternator output.



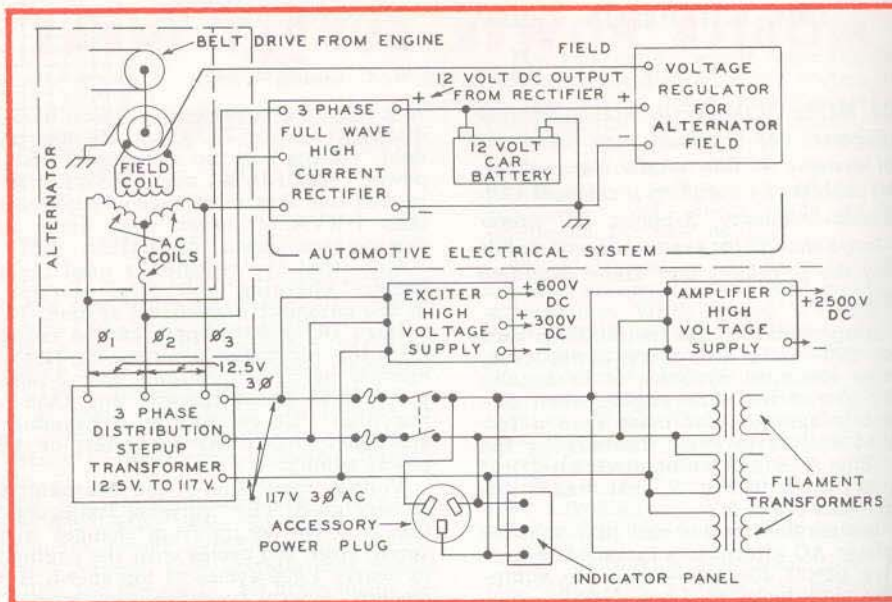

FIG. 3. DIAGRAM of the 3-phase automotive power system devised by the authors. The 3-phase 12.5-volt output from the alternator is stepped up to 117 volts with a home-made distribution transformer. Sufficient power for a full-kilowatt transmitter is available from the components specified in this article.

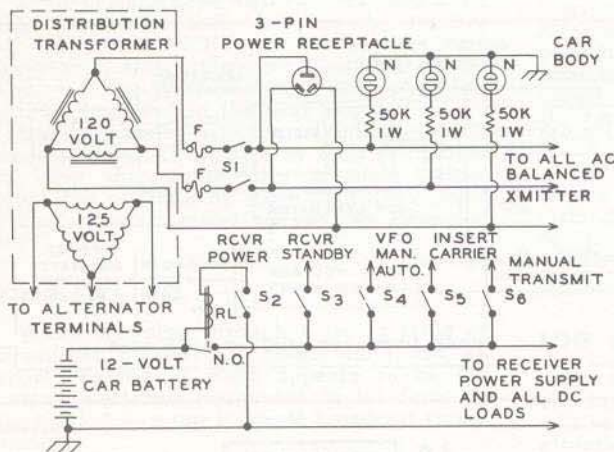

FIG. 4. CONTROL PANEL schematic diagram for the 3-phase AC electrical system. Fuses "F" and S₁ should be rated higher than the maximum current drawn from the AC circuit by the radio equipment. Switches S₂ to S₆ are SPST type toggles and energize DC relays which perform the functions indicated in the diagram.



W8DLD in the operator's seat of his high-power SSB mobile installation. Control panel is at center of dash, with voltmeters added to monitor the 12-volt DC and 117-volt AC circuits. Receiver is crystal converter into modified BC-453 Command Set tuner. Note hand key for CW operation just to left of steering wheel.

(continued from page 3)

Up to about 300 watts of DC power can be obtained from a 3-phase high voltage supply having transformers that step up the 12-volt AC alternator output to a few hundred volts. For higher power requirements, it is desirable to first step up the 12 volts to about 120 volts AC, and then use standard transformers in the high voltage DC power supply. This concept is illustrated in the complete mobile power supply systems used by W8DLD and W8WFH, shown in the diagram of Fig. 3.

The 3-phase distribution step-up transformers used in these installations, pictured on this page, were made by the authors. Constructional details are given in a folder which is available from the *G-E HAM NEWS* office. It also is possible to use three 12-volt to 120-volt step-up transformers with primaries and secondaries in a delta connection, but the efficiency and regulation may be not as good.

An essential part of the system is the control and indicator circuit shown in Fig. 4. All three neon lamps should light with the system in operation; one lamp not glowing indicates that one of the three AC phases may be grounded to the car. The polarized 3-prong plug is handy for operating soldering irons and other accessories. Control switches S_1 to S_3 operate 12-volt DC relays to perform the required functions.

Once the alternator installation is complete and the regulator is working properly, test the regulation of the 120-volt distribution transformer with the lamp load shown in Fig. 5. Measure the voltage in each phase with the three 60-watt lamps connected; it should be about 120 volts. Then close the DPST switch; about 110 volts should be indicated. Try this test at different engine speeds. The engine idling speed should be set so that the voltage reads at least 100 volts, with the full 780-watt load.

When planning the filament and plate power supplies for the radio equipment, make sure that a load balanced to within 5 percent is presented in the 3-phase system, both at 12 and 120 volts AC. Use three filament transformers for the equipment, one across each phase, with approximately the same power drains on each.

Plate power supplies designed for a 3-phase supply usually are closely balanced. Suggested circuits for high-voltage supplies are shown in Figs. 6 through 10. Characteristics of the various circuits are shown in TABLE I. Note that 3-phase rectifier circuits — particularly the full-wave types — feature low ripple voltage, low peak inverse voltages on the rectifiers, and high output voltage.

Use whatever components are available — rectifier tubes if you have filament transformers for the circuits of Figs. 6 and 7 — or silicon rectifiers in the circuits of Figs. 8, 9 and 10. Only 4 to 6 mfd. or filter capacitance is required on power supplies for r.f. equipment; a small 4-henry choke and two

(continued on page 7)

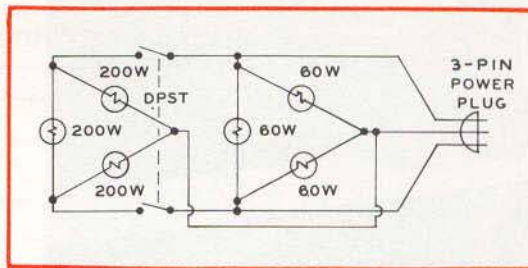
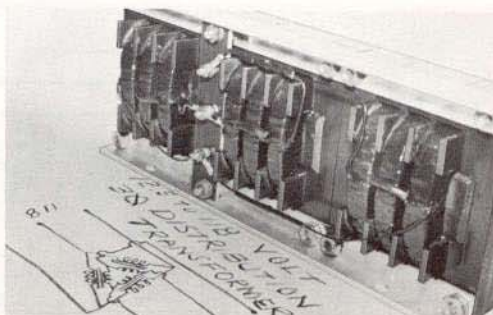

FIG. 5. CIRCUIT DIAGRAM for a 780-watt load with which the alternator may be tested after installation. Three 200-watt, and three 60-watt 117-volt lamps are used as loads across each of the three AC phases from the distribution transformer.



ENGINE COMPARTMENT VIEW of W8DLD's station wagon, showing Leece-Neville alternator in foreground and 3-phase distribution transformer mounted just ahead of it next to radiator.



DISTRIBUTION TRANSFORMER completely assembled and ready for installation. Entire transformer has been impregnated with insulating varnish to protect it from the moisture present in hot weather.

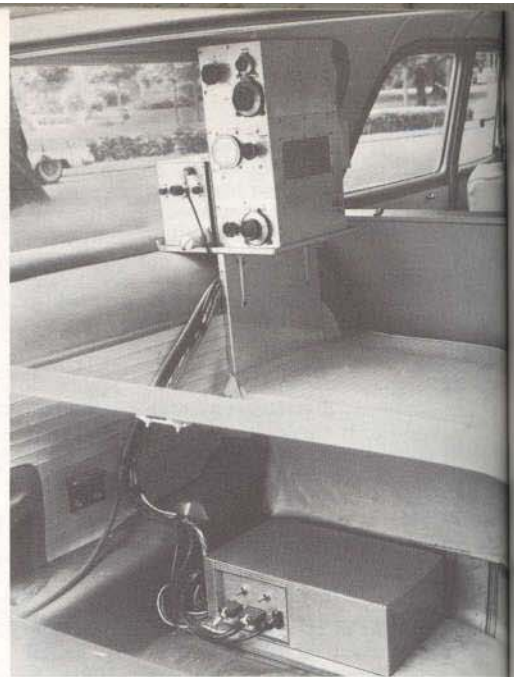

INSTALLATIONS OF POWER SUPPLIES and linear amplifiers in W8DLD's (left) and W8WFH's (right) station wagons. Storage compartments under cargo decks are handy locations for high voltage power supplies, while r.f. equipment is fastened to shelves atop rear wheel housings.

BIBLIOGRAPHY OF ARTICLES ON THREE-PHASE MOBILE POWER SYSTEMS

"A Different Approach to High-Power Mobile," by J. Emmett Jennings, W6EI; *QST*, April, 1953, page 28; also *ARRL Mobile Manual*, page 202.

"Three-Phase Power Supply for Mobile Use," by J. Emmett Jennings, W6EI; *QST*, January, 1958, page 28; also *ARRL Mobile Manual*, 2nd edition, page 183.

"Inside Leece-Neville," by D. W. Potter, W2GZD; *CQ*, May, 1955, page 16.

"High Power Three-Phase Mobile Power Supply," by M. Stevens, W8IWG; *CQ*, October, 1955, page 15.

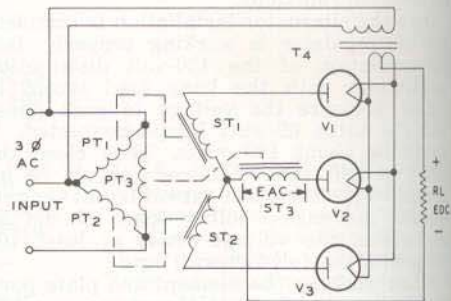

FIG. 6. 3-PHASE STAR HALF WAVE rectifier circuit for tube rectifiers. See Fig. 7 for component details.

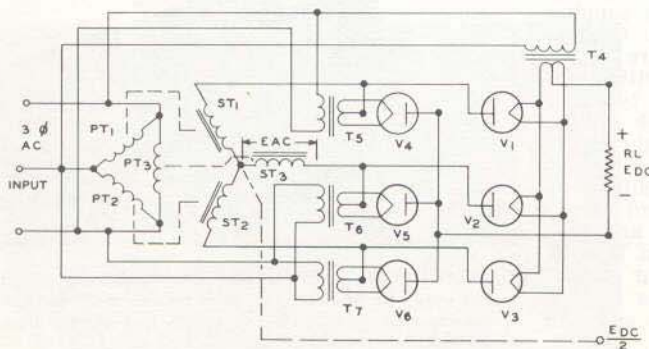

FIG. 7. 3-PHASE STAR BRIDGE full wave rectifier circuit for high vacuum (5U4-GB, 5AR4, etc.) and mercury vapor (GL-816, GL866A) rectifier tubes (V_1 to V_6). Transformers T_1 , T_2 and T_3 (actually designated as "PT" and "ST" to indicate primary and secondary) are discussed in the text. Filament transformer T_4 should be rated for the current drain of three rectifier tubes; T_5 , T_6 and T_7 are rated for one tube each. See TABLE I for voltage, current and peak inverse ratings.

TABLE I — 3-PHASE RECTIFIER CHARACTERISTICS

FIGURE NO.	6	7	8	9	10
AC secondary volts per 1,000 DC volts.....	855	428	855	428	740
DC volts output per 1,000 AC volts.....	1,170	2,340	1,170	2,340	1,350
Permissible DC output current above rating of single rectifier.....	300%	300%	300%	300%	300%
Peak inverse voltage per leg per 1,000 DC volts.....	2,090	1,050	2,090	1,050	1,050
Ripple frequency.....	3 f	6 f	3 f	6 f	6 f
Ripple voltage as percentage of DC output voltage.....	18%	4.2%	18%	4.2%	4.2%

(continued from page 5)

4-mfd. capacitors in a "brute force" filter are sufficient for exciter and audio equipment.

W8DL D uses the circuit of Fig. 7 with six GL-816 rectifiers and three 830-volt secondary transformers (Stancor PC-8301) in his 2,000-volt DC supply. A 300/600-volt dual output supply, using the circuit of Fig. 9, was made with three 120-to-240-volt, 50-watt step-down isolation transformers (Chicago SD-50). This powers his exciter and supplies screen voltage for a pair of GL-814 pentodes in his linear amplifier.

W8W F H uses a similar 300/600-volt power supply, plus a high voltage supply with the circuit of Fig. 9 and three 1,030-volt transformers (Stancor PC-8302) to obtain 2,500 volts DC to operate a pair of GL-4D21/4-125-A's in his linear amplifier.

Many amateurs will find the 3-phase alternator system to be the answer to their mobile power supply problems, just as W8DL D and W8W F H have found that it makes home-station results in signal reports possible from their mobile installation.

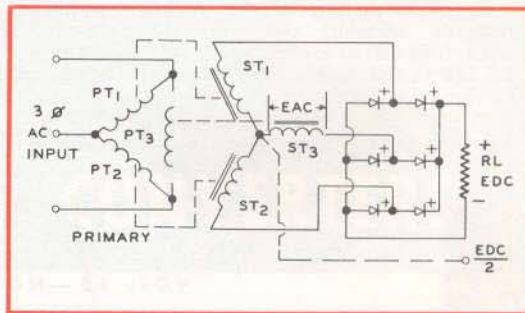

FIG. 9. 3-PHASE STAR BRIDGE rectifier circuit with silicon rectifiers. Approximately half to full DC output voltage can be obtained from the junction of the three high voltage windings, marked "EDC."

This half-voltage feature also can be obtained from the circuit in Fig. 7.

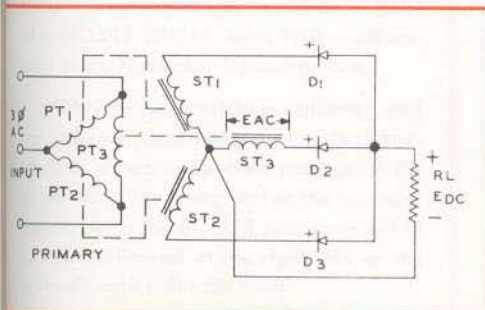

FIG. 8. 3-PHASE STAR HALF WAVE rectifier circuit with silicon rectifiers at D₁, D₂ and D₃. More than a single rectifier in each leg of the circuit will be necessary for output voltages above 200 volts. G-E type 1N1695 silicon rectifiers are suitable.

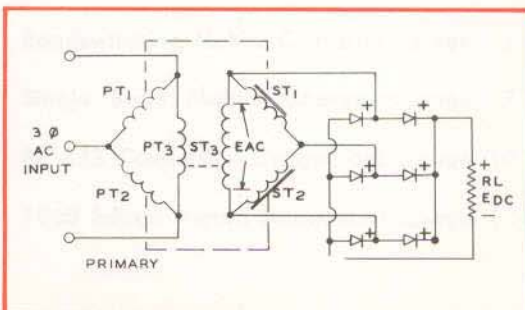
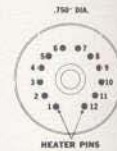
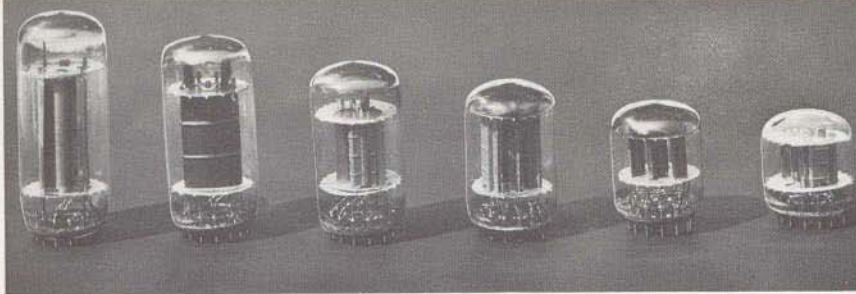

FIG. 10. 3-PHASE DELTA BRIDGE full wave rectifier circuit with silicon rectifiers. The "delta" connection of the high voltage windings reduces the DC output voltage to about 58 percent that of the star bridge circuit in Fig. 9, using the same transformers.



GENERAL ELECTRIC Announces...

COMPACTRON

**Multi-function
Devices**

A new electronic device that combines into one unit the functions now performed by several components has been announced by G.E.'s Receiving Tube Department.

Combining the functions of two and more conventional miniature receiving tubes into a single envelope, "Compactron" devices make possible amateur communication receivers with four or five such envelopes containing all the functions now performed by a ten or eleven-tube receiver.

Table radios with two "Compactron" devices replacing the present five-tube lineup,

and television receivers with ten such devices containing the same circuitry now requiring fifteen tubes, also are envisioned. Significant reductions in cabinet size also are possible with this new component.

"Compactron" devices use a new 12-pin base with a pin circle 0.750 inches in diameter, shown above at the right. Seated heights (see photo above) range from 1 to 2 3/4 inches, with a bulb diameter of 1 1/8 inches. They will be in production soon. *G-E HAM NEWS* is planning construction articles containing "Compactron" devices for 1961.



JULY-AUGUST, 1960
VOL. 15—NO. 4

HOW-TO-DO-IT IDEAS

from the 999 radio amateurs at

GENERAL ELECTRIC

published bi-monthly by
RECEIVING TUBE DEPARTMENT
Owensboro, Ky.

Available **FREE** from your
G-E Tube Distributor

E. A. Neal, W4ITC — Editor

